

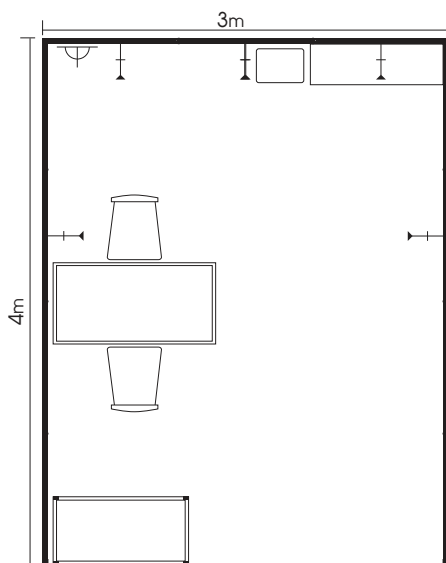

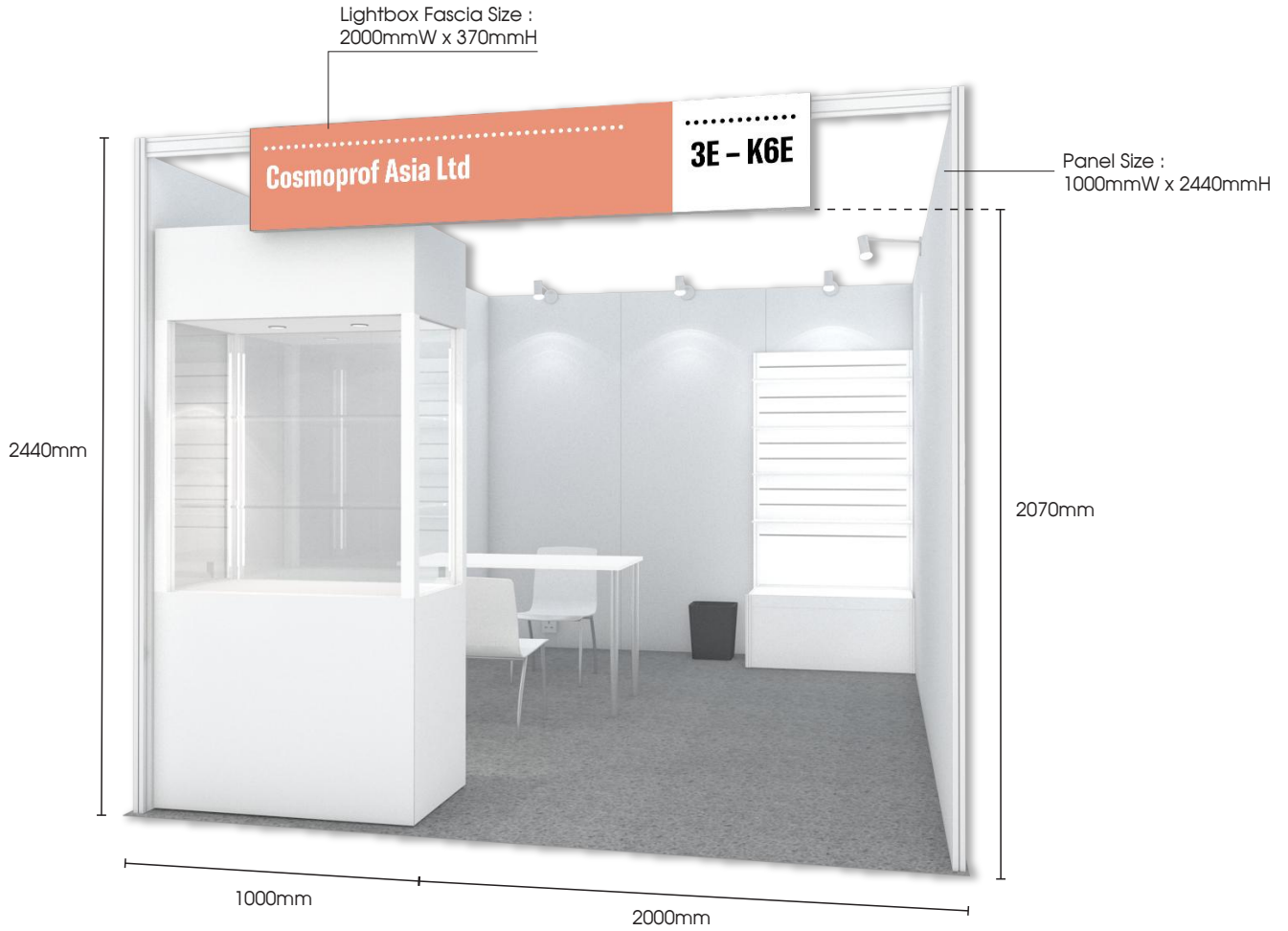





COSMOPROF ASIA
 READY STAND

3m x 4m Ready Stand
 (For reference only, not to scale)

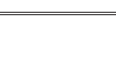

-  Wall Panel, white in colour @ height 2440mm
-  Lightbox Fascia
-  12W LED Longarm Spotlight (EL7076W)
-  13Amp Square Pin Socket (EL7005)
-  950mm Slat Wall with 4 x Shelving (SF3039 or SF3040)
-  Lockable Showcase as supplied with Ready Stand (SF3034 or SF3035) 1000mm(W) x 500mm(D) x 2100mm(H) or 1150mm(H)
-  Waste Paper Basket (AF5018)
-  White Chair (TC4060)
-  White Table (TC4059) 1200mm(W) x 600mm(D) x 750mm(H)

3m x 4m Ready Stand

One side open, 12sqm.

1 X LIGHTBOX FASCIA,
 COMPANY NAME AND STAND NUMBER

1 X SHOWCASE (FIXED)
 1000mm X 500mm x 2100mm(H) or 1150mm(H)
 Lockable Tall (SF3034) or Table Showcase (SF3035)

4 X SHELVING ON 1 SLAT WALL (ADJUSTABLE)
 950mm X 300mm(D) White Flat (SF3039)
 or Slope (SF3040) Shelving

1 X TABLE
 White Table (TC4059)

2 X CHAIR
 White Chair (TC4060)

5 X SPOTLIGHT (FIXED)
 12W LED Longarm Spotlight (EL7076W)

1 X POWER SOCKET (FIXED)
 13Amp Square Pin Socket (EL7005)

1 X WASTE PAPER BASKET (AF5018)

CARPET (GREY)

COSMOPROF ASIA
 READY STAND

READY STAND ITEMS PER SQM AREA

ITEM / STAND SIZE	CODE	12-15 SQM		16-19 SQM		20-23 SQM		24-27 SQM		28-31 SQM		32-35 SQM		OVER 36 SQM	
STAND TYPE A=AISLE READY STAND C=CORNER READY STAND	-	A	C	A	C	A	C	A	C	A	C	A	C	A	C
STOREROOM - 1 SQM 1000mm X 1000mm X 2440mm(H)	-	N/A	N/A	1	1	1	1	N/A	N/A	N/A	N/A	N/A	N/A	N/A	N/A
STOREROOM - 2 SQM 2000mm X 1000mm X 2440mm(H)	-	N/A	N/A	N/A	N/A	N/A	N/A	1	1	1	1	1	1	1	1
LIGHTBOX FASCIA	-	1	2	1	2	1	2	1	3	1	3	1	3	1	3
WHITE TABLE 1200mm X 600mm X 750mm(H)	TC4059	1	1	1	1	1	1	2	2	2	2	2	2	2	2
WHITE CHAIR	TC4060	2	2	3	3	4	4	4	4	8	8	8	8	8	8
SPOTLIGHT 12W LED Longarm Spotlight	EL7076W	5	5	6	6	7	7	9	9	11	11	12	12	13	13
13AMP SQUARE PIN SOCKET 220V / 500W MAX.	EL7005	1	1	1	1	1	1	1	1	1	1	1	1	2	2
WASTE PAPER BASKET	AF5018	1	1	1	1	1	1	2	2	2	2	2	2	3	3
SHOWCASE OPTIONS: (A) TALL SHOWCASE 1000mm x 500mm x 2100mm(H) OR (B) TABLE SHOWCASE 1000mm x 500mm x 1150mm(H)	SF3034 OR SF3035	1	1	1	1	1	1	2	2	3	3	3	3	3	3
SLAT WALL 1020mm X 500mm X 2000mm(H)	SF3036	1	1	1	1	2	2	2	2	3	3	4	4	4	4
SHELVING OPTIONS: (C) FLAT SHELF (Maximum loading for each shelf is 5kg) 950mm x 300mm(D) OR (D) SLOPE SHELF (Angle for slope shelf is 30 degree) 950mm x 300mm(D)	SF3039 OR SF3040	4	4	4	4	8	8	8	8	12	12	16	16	16	16

COSMOPROF ASIA

SHOWCASE OPTIONS (for all Sectors) : Refer to Form 4a
 Please choose a Showcase supplied in the Ready Stand Package.

OPTION A

Tall Showcase with 2 Halogen Downlights and 2 LED Lighting Strip
 Size : 1000mm(L) x 500mm(W) x 2100mm(H)

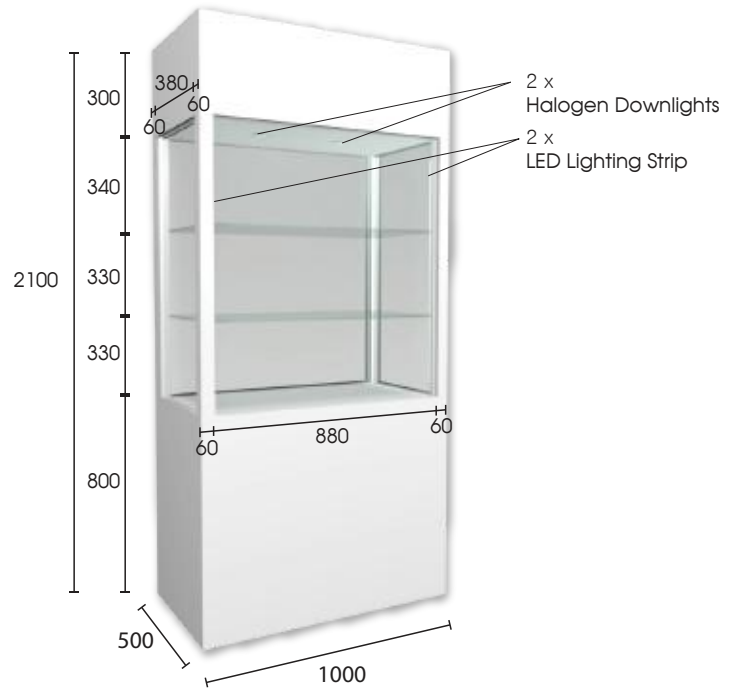

OPTION B

Table Showcase with 1 LED Lighting Strip
 Size : 1000mm(L) x 500mm(W) x 1150mm(H)

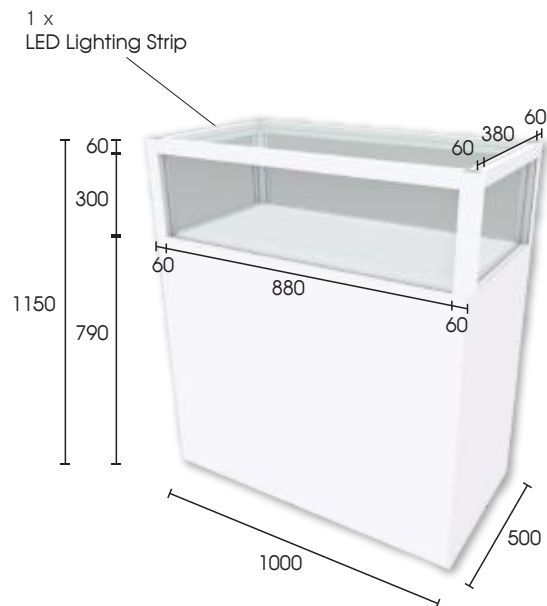
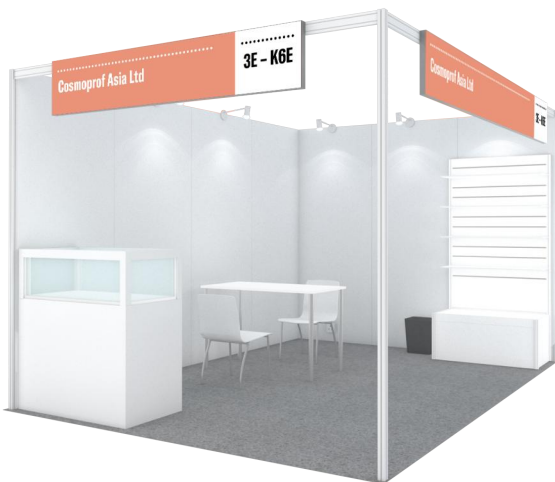

WALL PANEL, FASCIA AND CARPET COLOUR REFERENCE GUIDE

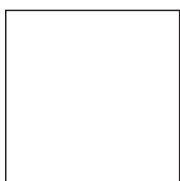

Wall Panel Laminate
 White

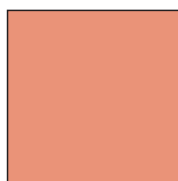

READY STAND FASCIA
 PANTONE 486 C

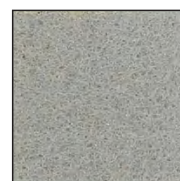

READY STAND CARPET
 GREY - Expo-tex 0916 Grijsclair

Remarks :

Wall Panel Size : 1000mm(L) x 2440mm(H)

(Please consider the spotlight holder at the top of the wall panel, supporting pole at the corner and in the frontage (if any) of the stand when consider poster, foamboard arrangement, see drawing for reference.)

IMPORTANT INFORMATION FOR EXHIBITORS REGARDING THE READY STAND PACKAGES

- To maintain the overall ready stand image, stand constructions including the stand fascia, stand wall and carpet must be retained. However, should exhibitors wish to revise the fascia design (Such as adding company/ brand logo or change the carpet color, please contact Official Stand Contractor for a separate quotation.
- The specification details for all sizes of Ready Stand packages are listed in a table on the previous page.
- Every 6m frontage requires a pole (provided free of charge by the Official Stand Contractor).
- If the Exhibitor wishes to relocate or remove any items of his supplied Ready Stand, it is necessary for him to redraw his revised stand layout on Form 4f. Provided that sufficient prior notice is given to the Official Stand Contractor, such changes can be made free of charge. Removed/ unwanted Ready Stand items cannot, however, be exchanged for other items.
- A charge will be levied by the Official Stand Contractor for any on-site removal or relocation of items from the supplied Ready Stand.
- If the exhibitor orders any additional items without attaching their location plan (Form 4f), AMC (Exhibits) Ltd will position the ordered items as it sees fit.
- No nailing, drilling, painting or fixtures of any kind are allowed on the partitions, floor, ceiling or any hall/stand structure. Should exhibitor require affixing poster / foamboard on the ready stand panels, only Velcro may be used and this must be removed completely when the show is finished. Should any damage occur, it is the exhibitors / appointed contractor's responsibility to meet the costs involved. (Please refer to next page for further details.)
- No fixtures or nails are permitted to any part of the Exhibition Centre and Exhibitors must ensure that arrangements be made in their own designs for all parts of their work to be self-supporting and secure.
- Any features or graphic panels on stands are not permitted to encroach the common air space outside the area booked and should remain within the boundaries of the stand. The Organisers have the right to authorize dismantling or rebuilding of

Ready Stand Exhibitors are strongly advised to contact the Official Stand Contractor to check the exact dimensions of wall panels, showcases, etc, if interior decorations are to be made. (e.g. posters, stickers, etc.)

Dear Exhibitors

This is to advise all exhibitors that lamination of graphics (wall papering) directly on the system panels, using screws, nails, double-sided adhesive tape that will cause damage to the panel walls is strictly prohibited. Exhibitors are responsible for removing the laminated graphics and restore the panel system at the close of the show. A restoration fee will be charged to exhibitors for damage to panel walls.

Using proper materials and procedure will allow graphic to be applied correctly. The following materials for laminating graphics are strongly recommended.

Namely:

- A** Velcro Tape / Magic Tape **B** Good quality double-sided tape **C** S Hooks

Here is how to use Velcro Tape / Magic Tape to laminate graphics:

A
 Velcro Tape / Magic Tape

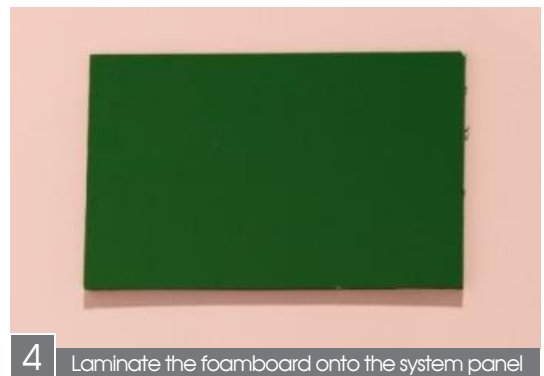

Can also use good quality double-sided tape or S Hooks

B
 Good quality double-sided tape



C
 S Hooks

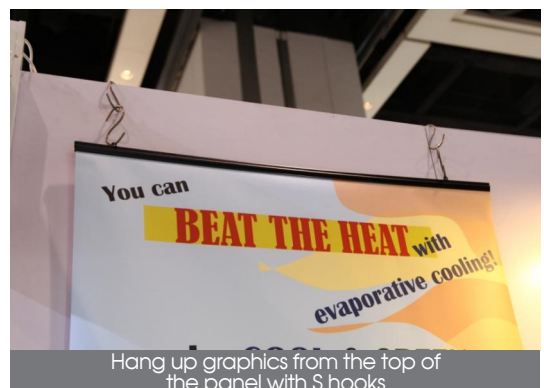

Here are some examples of lamination of graphics and applying double-sided adhesive tape (wall papering) directly on the system panels and the damage caused.

Double "Foam" Tape / lamination of low quality sticker directly onto panels

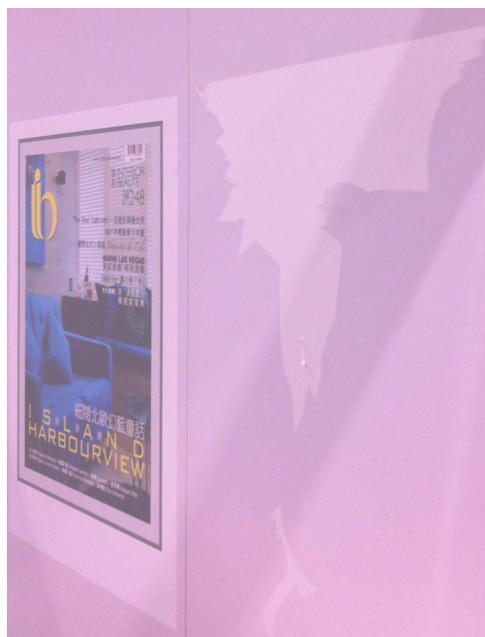
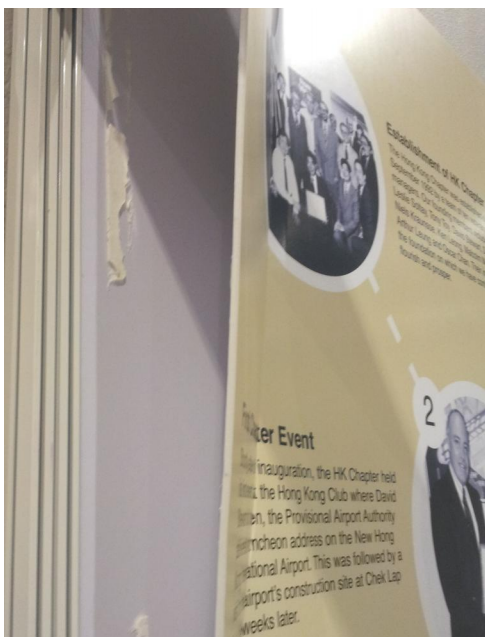
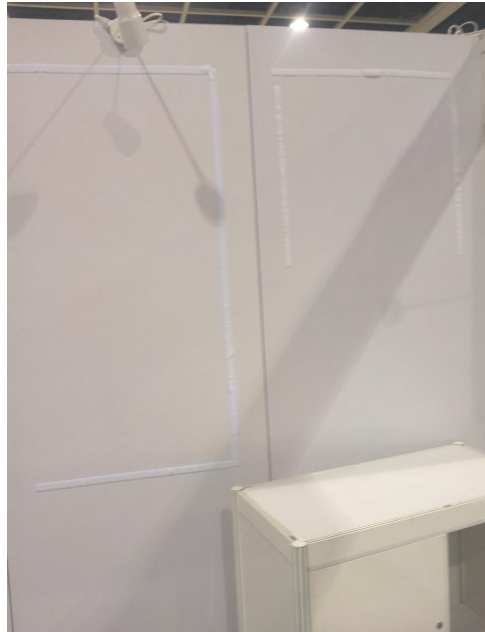

If the panels are damaged, a restoration fee of HK\$2,000.00 will be charged per panel.

*Velcro Tape / Magic Tape, good quality double-sided tape or S Hooks are available for sale at the onsite service counter.

Thank you for your understanding and co-operation.

Yours faithfully
 AMC (Exhibits) Ltd
 Official Contractor for Cosmoprof Asia

COSMOPROF ASIA
 READY STAND

4m x 4m Ready Stand
 (For reference only, not to scale)

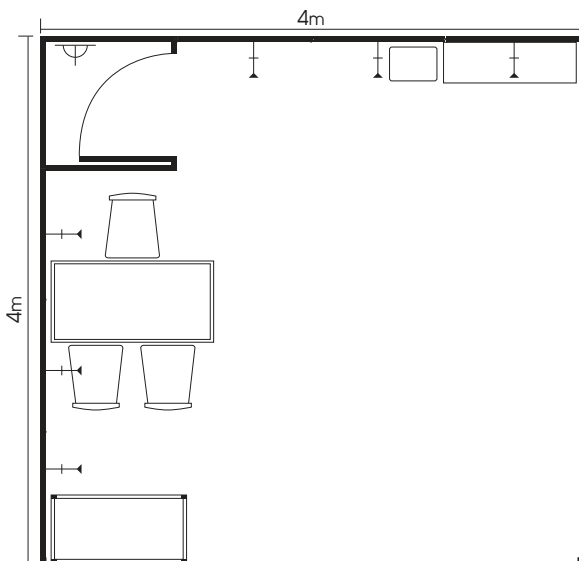

4m x 4m Ready Stand

Two sides open, 16sqm.

- 2 X LIGHTBOX FASCIA,
 COMPANY NAME AND STAND NUMBER
- 1 X STORAGE AREA (FIXED)
 1000mm X 1000mm x 2440mm(H)
- 1 X SHOWCASE (FIXED)
 1000mm X 500mm x 2100mm(H) or 1150mm(H)
 Lockable Tall (SF3034) or Table Showcase (SF3035)
- 4 X SHELVING ON 1 SLAT WALL (ADJUSTABLE)
 950mm X 300mm(D) White Flat (SF3039)
 or Slope (SF3040) Shelving
- 1 X TABLE
 White Table (TC4059)
- 3 X CHAIR
 White Chair (TC4060)
- 6 X SPOTLIGHT (FIXED)
 12W LED Longarm Spotlight (EL7076W)
- 1 X POWER SOCKET (FIXED)
 13Amp Square Pin Socket (EL7005)
- 1 X WASTE PAPER BASKET (AF5018)
- CARPET (GREY)

COSMOPROF ASIA
READY STAND

6m x 4m Ready Stand
(For reference only, not to scale)

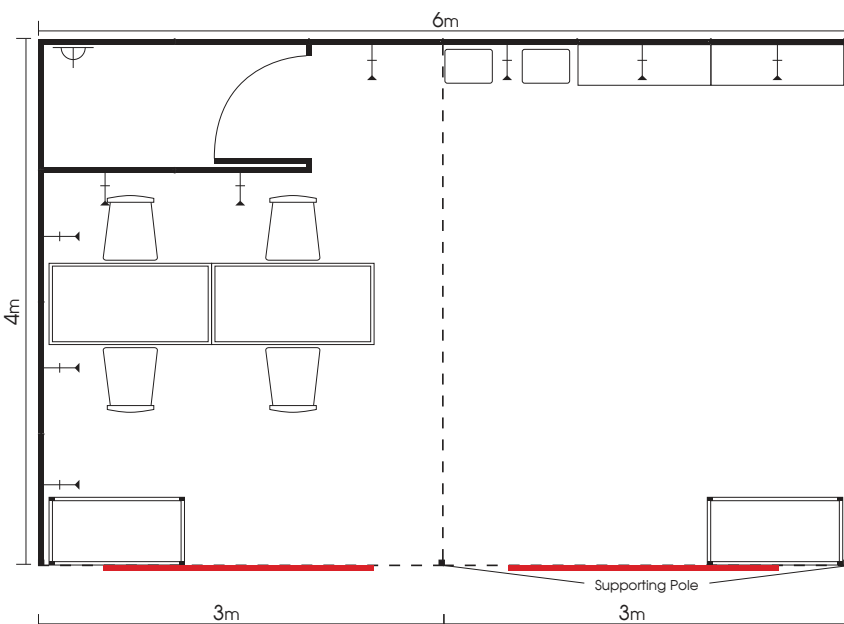

6m x 4m Ready Stand

Two sides open, 24sqm.

3 X LIGHTBOX FASCIA,
COMPANY NAME AND STAND NUMBER

1 X STORAGE AREA (FIXED)
2000mm X 1000mm x 2440mm(H)

2 X SHOWCASE (FIXED)
1000mm X 500mm x 2100mm(H) or 1150mm(H)
Locakable Tall (SF3034) or Table Showcase (SF3035)

8 X SHELVING ON 2 SLAT WALL (ADJUSTABLE)
950mm X 300mm(D) White Flat (SF3039)
or Slope (SF3040) Shelving

2 X TABLE
White Table (TC4059)

4 X CHAIR
White Chair (TC4060)

9 X SPOTLIGHT (FIXED)
12W LED Longarm Spotlight (EL7076W)

1 X POWER SOCKET (FIXED)
13Amp Square Pin Socket (EL7005)

2 X WASTE PAPER BASKET (AF5018)
CARPET (GREY)

COSMOPROF ASIA
 READY STAND

7m x 4m Ready Stand
 (For reference only, not to scale)



7m x 4m Ready Stand

Two sides open, 28sqm.

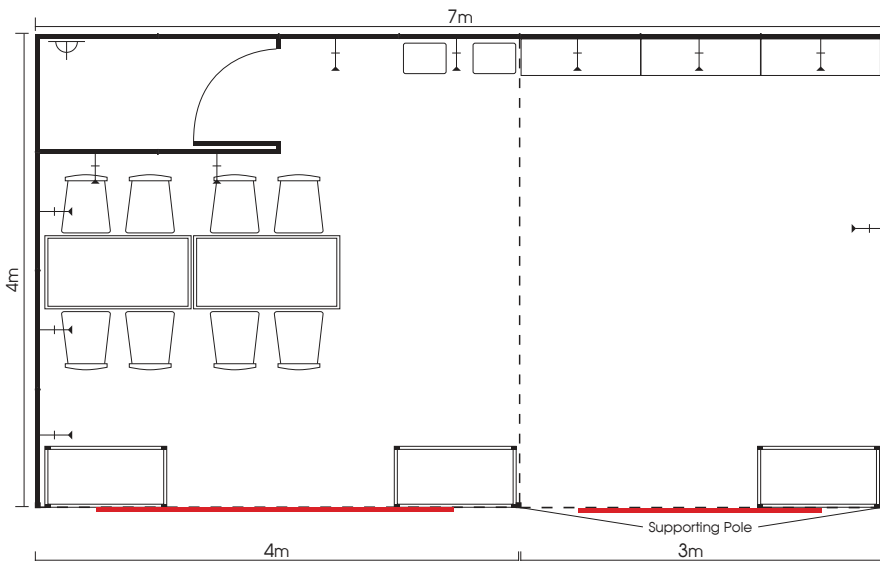

3 X LIGHTBOX FASCIA,
 COMPANY NAME AND STAND NUMBER

1 X STORAGE AREA (FIXED)
 2000mm X 1000mm x 2440mm(H)

3 X SHOWCASE (FIXED)
 1000mm X 500mm x 2100mm(H) or 1150mm(H)
 Lockable Tall (SF3034) or Table Showcase (SF3035)

12 X SHELVING ON 3 SLAT WALL (ADJUSTABLE)
 950mm X 300mm(D) White Flat (SF3039)
 or Slope (SF3040) Shelving

2 X TABLE
 White Table (TC4059)

8 X CHAIR
 White Chair (TC4060)

11 X SPOTLIGHT (FIXED)
 12W LED Longarm Spotlight (EL7076W)

1 X POWER SOCKET (FIXED)
 13Amp Square Pin Socket (EL7005)

2 X WASTE PAPER BASKET (AF5018)
 CARPET (GREY)

COSMOPROF ASIA
 READY STAND

8m x 4m Ready Stand
 (For reference only, not to scale)

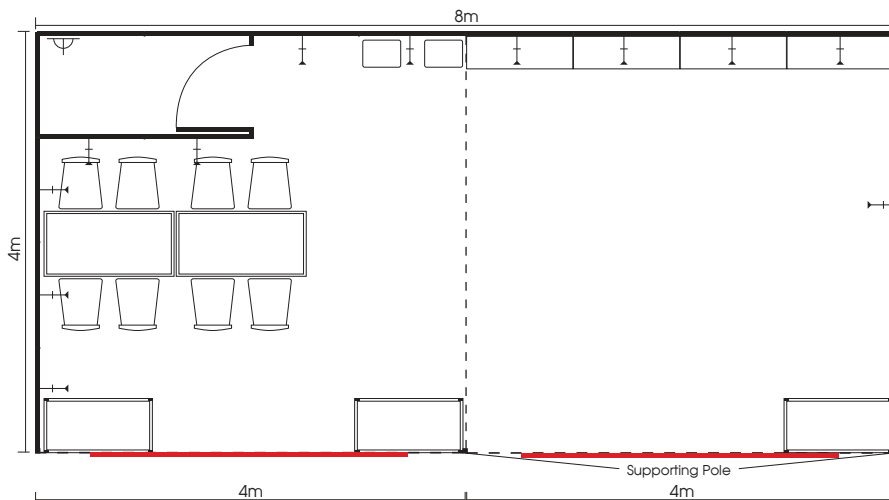

8m x 4m Ready Stand

Two sides open, 32sqm.

- 3 X LIGHTBOX FASCIA,
COMPANY NAME AND STAND NUMBER
- 1 X STORAGE AREA (FIXED)
2000mm X 1000mm x 2440mm(H)
- 3 X SHOWCASE (FIXED)
1000mm X 500mm x 2100mm(H) or 1150mm(H)
Locatable Tall (SF3034) or Table Showcase (SF3035)
- 16 X SHELVING ON 4 SLAT WALL (ADJUSTABLE)
950mm X 300mm(D) White Flat (SF3039)
or Slope (SF3040) Shelving
- 2 X TABLE
White Table (TC4059)
- 8 X CHAIR
White Chair (TC4060)
- 12 X SPOTLIGHT (FIXED)
12W LED Longarm Spotlight (EL7076W)
- 1 X POWER SOCKET (FIXED)
13Amp Square Pin Socket (EL7005)
- 2 X WASTE PAPER BASKET (AF5018)
- CARPET (GREY)